

uneek

EDUCATIONAL SOLUTIONS

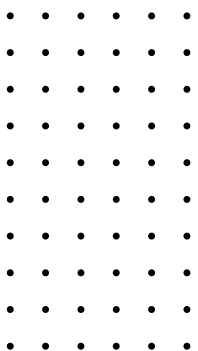
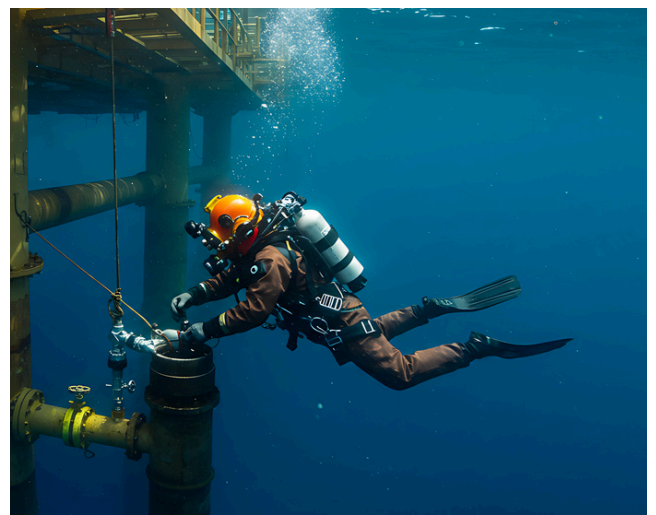
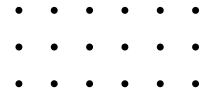

NDT AND WELDING EDUCATION BROCHURE

www.uneekeducationalolutions.com

COMPANY PROFILE

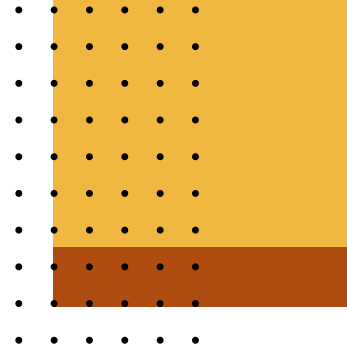

Pacific NDT is a distinguished US-based NDT & Security X-Ray Equipment manufacturer that specializes in delivering cutting-edge portable digital imaging solutions for NDT and Security applications. Our unwavering company mission revolves around pioneering unique and state-of-the-art digital X-Ray imaging technologies within the NDT and Security sectors, all while ensuring exceptional value and top-notch customer service.

At Pacific NDT, we have consistently been at the forefront of introducing advanced NDT Radiography solutions to the market. Our dedicated team comprises highly experienced Mechanical, Electrical, and Software Engineers who collaborate harmoniously to transform tailored X-ray solutions into reality.

Over the years, we have garnered a solid reputation as a NDT Radiography Company for satisfying clients across various industries, including Security, Forensics, Concrete, Pipeline, Powerline, and Aerospace imaging. We take pride in our commitment to pushing the boundaries of technology to provide innovative solutions for our customers' diverse needs.

www.pacificndt.com



PiX Rainier CT System

The PiX Rainier CT System brings together cutting-edge detector technology and a powerful microfocus X-Ray source. By combining the micron-level resolution, rapid scan capability and flexible system design, the PiX Rainier CT is built to meet and exceed the expectations of modern research labs, engineering teams, and production quality control environments

Developed and manufactured by Pacific NDT, the PiX Rainier CT system brings together cutting-edge detector technology and a powerful microfocus X-ray source with a 5 m focal spot to deliver unmatched clarity and precision. By combining true micron-level resolution, rapid scan capability, and flexible system design, PiX Rainier CT is built to exceed the expectations of modern research labs, engineering teams, and production quality control environments. Whether you are analyzing complex materials, inspecting electronic assemblies, or ensuring product integrity, PiX Rainier CT provides the clarity, speed, and reliability you need to make confident decisions. Designed in the Pacific Northwest and fully assembled in the United States, ensuring the highest standards of engineering excellence and long-term support.

High-Resolution CMOS Detector

- 50 μm pixel pitch CMOS detector optimized for industrial CT
- High frame rates enable rapid data acquisition for time-sensitive workflows
- Flexible 2x2 binning mode enhances throughput when needed

Microfocus X-ray Source Options

- Configurable from 90 kV up to 240 kV, adaptable to a wide range of materials and applications
- 5 μm focal spot size for high-definition, micron-scale imaging
- Stable, high-brightness output for crisp, distortion-free imaging
- Geometric Magnification up to 30x

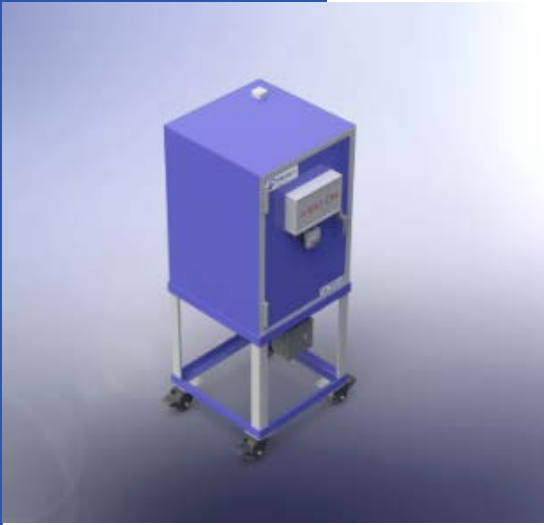
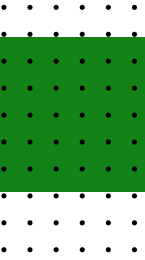

PiX MiniHD

X-Ray Cabinets

Pacific NDT is excited to introduce its stationary cabinet based X-Ray solutions along with its field proven successful portable imaging systems.

Critical Features

- Smallest form factor
- Highest pixel pitch Detector
- Small Focal spot x-ray for extreme sharpness
- Adjustable SID
- Radiation control using non-lead technology.
- High penetration power
- Robust design
- Large battery capacity (runs with Mains also)
- Designed for optimal cooling characteristics
- Safety Physical safety interlock with key
- Audible and visible warning signs
- Designed, Assembled and shipped from USA



PiX MosaiX

The MosaiX Imaging Solution is tailor made for large part inspection. MosaiX provides you a imaging area of 42" x 51" captured in minutes and the length of your imaging area can be extended using our sliding module attachments.

In addition to the X-ray of wings, the MosaiX solution is ideal for rotors, blades or large part automotive inspection, etc. MosaiX ensures flexible mounting solutions for multiple detectors with varying resolution, yielding the most efficient X-ray capture solution available.

Our Smart-Stitching feature, embedded in our software, captures MosaiX high resolution images and builds them precisely into large areas scans to ensure accuracy and integrity. Defects, as small as 25-50 microns, can be seen using our high definition detectors in sync with our small focal spot constant potential portable x-ray units making the MosaiX Imaging Solution the ideal choice for this industrial imaging discipline.

PIX RAVEN



POWERLINE SOLUTION

Introducing PiX Raven™ – introducing complete wireless solution for Powerline X-Ray Inspection designed for utility companies and transmission corporations. Powerline X-ray inspection is costly, difficult and sometimes just dangerous. PiX Raven is a highly advanced powerline mounting X-Ray solution designed to upgrade and introduce digital X-Ray imaging to the powerline industry.



PiX Raven includes a state-of-the-art digital detector inside our IP68 rated protective armor (Rhino), portable X-Ray, Air Pi Trigger Box all mounted on newly upgraded mount for inspecting sleeves and connectors. Our carbon fiber frame mounts on the powerline and is one of the safest methods to safely inspect conductor sleeves on power lines.

Along with it, our software loaded on a rugged tablet captures accurate and actionable images! With a single click, you can trigger the X-Ray, capture an image and wirelessly transfer it on to the table/laptop in a matter of seconds. When you launch the software, the detector and x-ray are auto-connected.

Inspect power lines efficiently & safely with PiX Raven™

- Auto Lock mechanism holds the Raven in place allowing no movement or blur during usage.
- With a single click, unlock & move the Raven to the next spot for inspection.
- Wireless transmission to touch screen tablets and laptops using Pacific NDT Powerline Software.

Software Features:

Viewing Tools – Rotate, Flip, Move, Zoom, Magnify, Best Fit, View 1:1, Adjust Contrast, W/L etc.



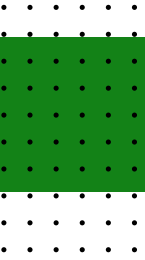

Specialized Industrial Applications
PiX Piken is ideal for a wide range of industrial radiography applications, including:

- Pipeline X-Ray Inspection
- Weld Inspection
- Structural Integrity Assessment
- Thickness Measurement

Pix Piken

NDT X Ray Machine

PiX Piken HD is our lightest, smallest and highest resolution imaging solution (NDT X Ray Machine).

PiX Piken: Portable NDT Digital Radiography Solution for Industrial Applications

PiX Piken is a compact, lightweight portable NDT digital radiography (DR) solution designed for maximum versatility and performance. This portable weld X-ray machine is housed in a compact Pelican case with custom foam, ensuring durability and easy transportation. Specifically engineered for Profile Radiography, it delivers detailed cross-sectional images of critical components with precision and reliability.



Bendable Digital X-ray Detectors:

Introducing PiX 410C: the most advanced bendable digital detector available in the market. 410C has the highest pixel pitch currently available for a bendable detector. It also comes with a rugged exterior case to withstand rigors of NDT use. Having a portable and lightweight form factor, its unique flexible design allows for reduced geometric distortion & enhanced detail resolution.

At Pacific NDT, we want to ensure that our products offer customers a plug and play experience while ensuring a long term use to maximize their ROI.



PiX 417c

NDT X Ray Machine

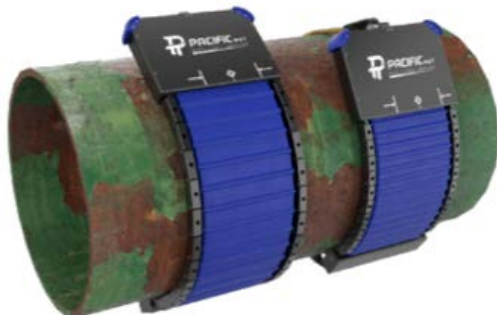

The PiX 417C is one of three rugged, bendable panel detectors (BPD) offered by Pacific NDT. As indicated by its name, the PiX 417 features a 4" wide by 17" long active sensor area, making it ideal for imaging cylindrical vessels and pipelines. Built for field use in extreme NDT environments, the PiX 417C delivers outstanding performance with Pulse Potential X-Ray, Constant Potential X-Ray, and Gamma Ray sources.

At Pacific NDT, we focus on delivering a seamless plug-and-play experience with our products, ensuring long-term reliability to help customers maximize their ROI.

The PiX 417C is a bendable panel detector engineered with flexible, durable materials, allowing it to conform seamlessly to curved or irregular surfaces like pipelines and cylindrical objects. Its innovative design ensures the detector bends without sacrificing image quality or performance.

PiX Bendable detectors provide enhanced versatility for inspecting non-flat surfaces, offering superior positioning and improved image accuracy for specialized applications.

Our entire detector range is fully integrated with PiX acquisition software, which is continuously optimized to add value to our customers. The software includes essential features such as viewing, annotation, measurement, post-processing, storage, export, and advanced capabilities like NDT PACS (Picture Archiving & Communication System) and ADR (Assisted Defect Recognition).

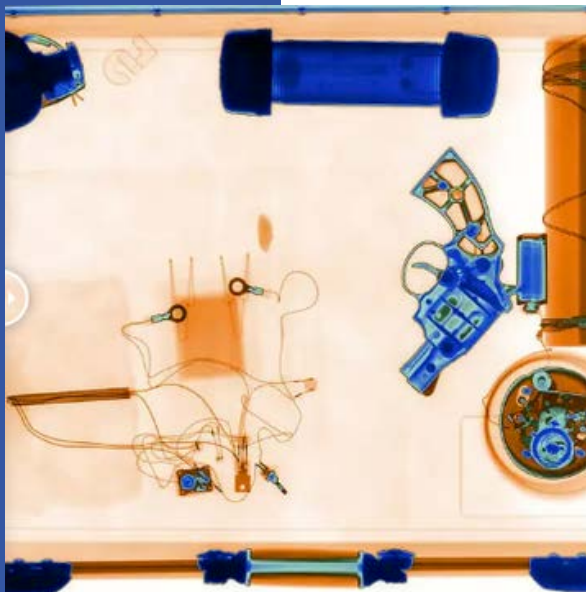

PiX (EzDR) 1417

The PiX Portable Security Solution from Pacific is designed with a complete focus on the end-user.

Every component has a snap-on fit for quick and definitive use in a high-pressure environment. The system carries certifications such as Military Standard 810G, 461G for usage in low and high temperature, vibration, and altitude, and is backed by Pacific's ISO 9001:2015 approved quality management system.

The system comes in a portable & rugged pelican case on wheels with custom foam (also available in a backpack solution). The imaging unit consists of an IP67 rated DR with the lowest edge space in the market, a rugged IP 65 PC/Tablet, PiX Security Software, PiX Gold 3.0 Control Box, Dual Energy Module (2.0), Golden XRS source & other accessories (bipod stand, tripod stand, etc).

The PiX Security Solution operates with a built-in battery and has both tethered & wireless modes. Our system enables you to capture and display an image in a matter of seconds, allowing you to make rapid decisions under high-pressure situations.

- Low Edge Space
- IP 67 Certified Detectors
- Complete Wireless X-Ray Control
- Emergency ON/OFF Switch
- Dual Energy Module
- Auto-Connect
- Visual and Audible Alarm
- Pelican and Backpack Solutions
- Long Range Image Transfer

PiX 1012HD

The PiX Security Solution from Pacific NDT is designed with a complete focus on the end-user.



Every component has a snap-on fit for quick and definitive use in a high-pressure environment. The system carries certifications such as Military Standard 810G, 461G for usage in low and high temperature, vibration, and altitude, and is backed by Pacific's ISO 9001:2015 approved quality management system.

The PiX Security Solution comes in a portable & rugged pelican case on wheels with custom foam (also available in a backpack solution). The imaging unit consists of an IP67 rated DR with the lowest edge space in the market, a rugged IP65 PC/Tablet, PiX Security Software, PiX Gold 3.0 Control Box, Dual Energy Module (2.0), Golden XRS source & other accessories (bipod stand, tripod stand, etc).



Water- & dust-resistant



Manufactured in USA



Completely wireless system



The carbon fiber covers are tough



Pix 0506HD NDT

50 Micron CMOS Detector

FEAURES

- 50 μm pixel pitch with 16-bit ADC
- CMOS detector technology
- 4.6 x 5.6 inch imaging area
- Gigabit Ethernet interface, without image loss
- Fast speed, high throughput
- IP65 ingress protection
- “Plug and Play” Software

PiX 0506 NDT is state-of-the-art, solid-state CMOS detector for dynamic imaging. The 5x6 inch CMOS sensor provides a dynamic range up to 72 dB, and supports programmable gain and read-out modes. It enable high speed imaging up to 18 fps with excellent sensitivity. The PiX 0506 NDT is suited for industrial NDT applications including aerospace imaging, BLC (bondline corrosion), microfocus inspection etc.

Pacific NDT specializes in providing high quality x-ray imaging solutions for industrial and security use. We are based in the beautiful Pacific Northwest (Seattle, WA) and all of our designs, assembly & manufacturing is done in the USA. We have a range of Computed Radiography (CR) and Digital Radiography (DR) products powered by PiX (acquisition software). wide range of applications including Aerospace, Oil & Gas, Powerline, Pipeline Integrity, Concrete, Security, Automotive, Battery Inspection etc.

Our company mission is to have successful installations in as many countries as possible while ensuring excellent post sales service. Our software is available in English, Spanish, Portuguese, German & Chinese. Local language software is available upon request of the product.

COMPANY PROFILE

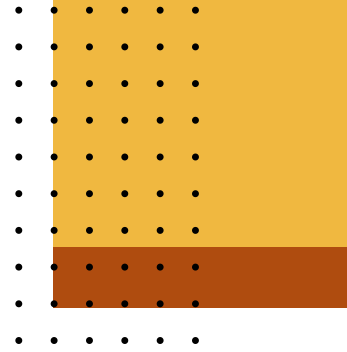

We started over 25 years ago as non-destructive testing technicians who wanted to change the way ultrasonic scanning was performed. Our goal was to design ultrasonic scanners/robots that are innovative, reliable, and efficient. We continue to push the boundaries of technology by developing some of the most powerful and robust scanners on the market. With our extensive field experience, we understand that every aspect of an ultrasonic scanning system is crucial for a successful inspection. That's why we engineer everything—from the software to the transducer and scanner—with the inspector in mind.

At ScanTech, we specialize in designing and manufacturing application-specific ultrasonic scanning systems. Our turn-key solutions are ideal for various applications, including:

- Storage Tank Wall Inspection
- Pipeline and Pressure Vessel Corrosion Mapping
- Automated and Manual Weld Inspection
- Phased Array and Conventional UT Scanners
- Robots for Flexible DR (Digital Radiography)

By providing fully integrated systems and comprehensive training, we enable our customers to leverage the latest tools while focusing on their core inspection services. Our extensive inventory and commitment to service ensure that our customers remain productive during critical inspections. We prioritize design excellence, innovation, quality, and customer service.

www.ScanNDT.com

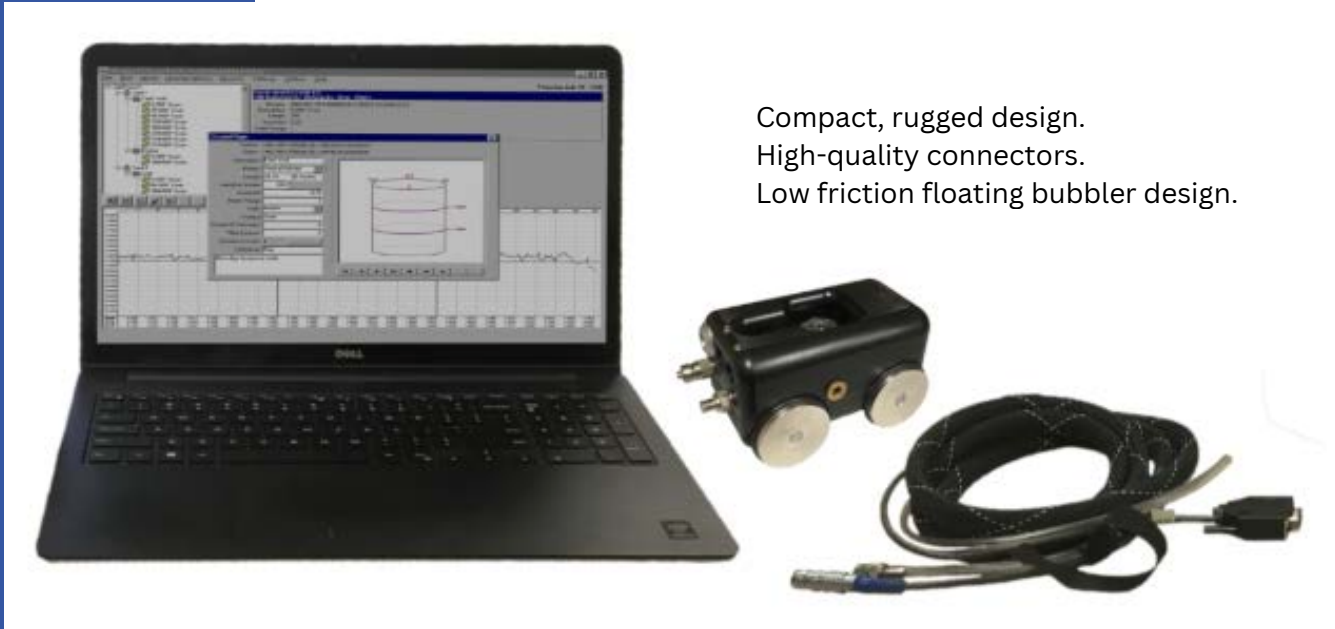

Compact, rugged design.
High-quality connectors.
Low friction floating bubbler design.

H3

Manual Inline B-Scanner

KEY FEATURES

Compact, Rugged Design: Built to withstand harsh environments with minimal maintenance.

- Advanced Couplant Recirculation System: Reduces noise and enhances signal quality for clearer results.
- Low Friction Floating Probe Shoe: Reduces wear and maintenance, ensuring smooth operation.
- Interfaces with Analyst X B-Scan Software: Provides user-friendly data acquisition and reporting.
- Optional Telescoping Pole: Extends reach for scanning hard-to-access areas.



X3 Spider

Semi-Automated B-Scanner for Storage Tanks

- Software: Analyst X Provides Data Acquisition, Analysis and API 653 Reporting
- Flexible Power Options: Operates from AC or DC
- Transducer Options: Available with single or dual element transducers
- Adjustments: Easy Wheel Angle Adjustments for Axial Travel
- High Maneuverability: Traverses Difficult Obstructions (Up to 2" High)
- Probe Design: Reduces Turbulence and Water Consumption while Providing Consistent Contact Force
- Direct Drive Gear Set: Eliminates Slippage while Maximizing Drive Power

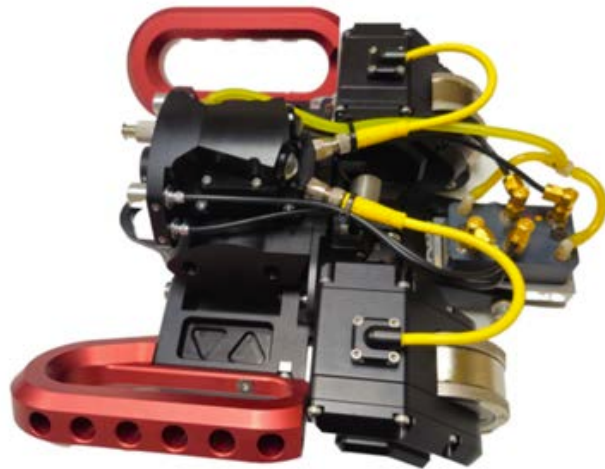

Axis

The Ultimate Power and Precision in Scanning

The Axis Scanner is a state-of-the-art scanning platform engineered to deliver high power density and exceptional versatility in industrial settings. Built on ScanTech's advanced Wheel Pack™ (WP) platform, this scanner is designed to perform ultrasonic B-Scans with precision and efficiency on small radius vessels, dryer rolls, and piping. The Axis Scanner combines robust, field-tested components with cutting-edge technology, ensuring unmatched reliability, performance, and ease of use.

This scanner meets the demanding requirements of industrial inspections. It offers superior adhesion on vertical and inverted surfaces, precise positioning, and high-quality data return, while maintaining a lightweight and portable design.

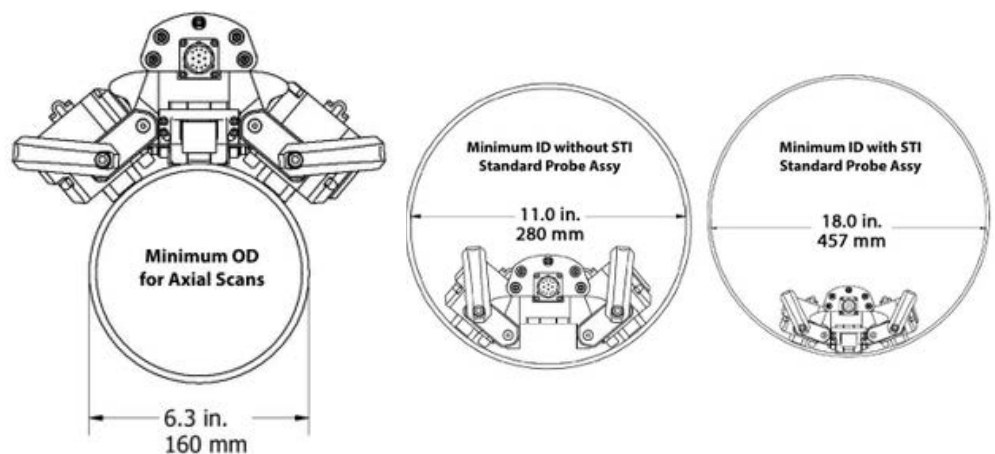



APEX

The universal All-In-One scanner
Compatible for use with Phased Array Inspection Methods

The Apex Scanner is a modular, universal scanning platform designed for high-precision and versatile scanning applications. It combines rugged, field-proven components with advanced technology to ensure reliability and portability in various industrial settings.

This Scanner is designed to meet the rigorous demands of industrial inspections, offering unmatched versatility and performance.



- Incorporates Years of Engineering Knowledge into one Scanner
- Modularity—Toolless attachments for B-Scan, Front Mount Raster Arm, and Side Mount Raster Arm
- Anti-Tip Probe Mechanism with Equal Force Throughout Vertical Compliance



B-Scan



C-Scan Front Arm
Pipe OD \geq 6"



C-Scan Side Arm
Pipe OD \geq 3"



High Resolution (down to 0.0125" x 0.0100")

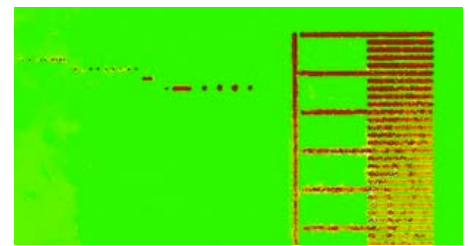



Radix

Modular Weld Inspection Platform

The Radix is an advanced weld inspection platform designed for both automated and manual inspection in industrial environments. Its modular design offers unmatched flexibility and precision, ensuring superior performance across various applications. Engineered to adapt to diverse weld geometries, the Radix provides reliable, high-quality data in even the toughest conditions.

Built with ScanTech's industry-leading technology, the Radix incorporates cutting-edge features for enhanced usability, efficient weld inspections, and seamless integration into existing workflows. The Radix platform is the perfect solution for NDT professionals seeking accuracy, durability, and ease of use.

Weld Inspections: The Radix is specifically designed for weld inspections, providing high-quality data and ensuring precise weld integrity assessments across different materials and structures.

Automated and Manual Inspections: The Radix can be deployed for both automated and manual inspections, providing flexibility and ease of use in a wide range of environments.



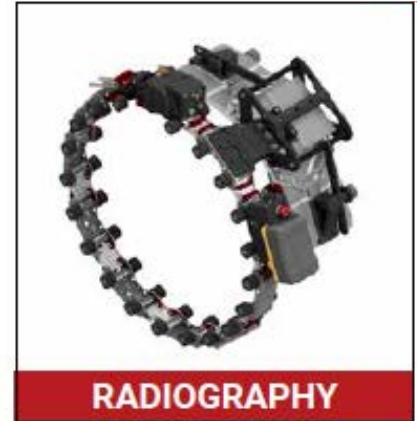

CLIX

Modular Chain Scanner

The CLIX is your solution for Weld Inspection (WI), Corrosion Mapping (CM) or Radiography (RT). Chain-driven stability for precise weld scanning on small to large pipe diameters. Configurable to suit various access points. 100% wireless RT scanning capability for maximum mobility and operator safety. Quick change arm lengths for scanning both short and extended pipe sections.

FEATURES

Multi-Method Inspection

- Perform weld inspection, corrosion mapping, and radiographic testing with a single modular platform.
- Supports manual, motorized umbilical, or wireless operation, for both ferrous and non-ferrous surfaces.

Flexible Diameter Coverage

- Chain link design expands to any pipe diameter with consistent, secure linking for precise scans.

Quicklinks

- Quick-connect chain links allow fast diameter changes for pipe sizes from 6" to 48".

Heavy-Duty Payload Capacity

- Supports large probes, multiple probe holders, without compromising stability.

Wheel Pack Assembly

- Integrated Wheel Pack Assembly (WPA) ensures smooth motorized travel, strong traction, and compatibility across multiple configurations.

COMPANY PROFILE

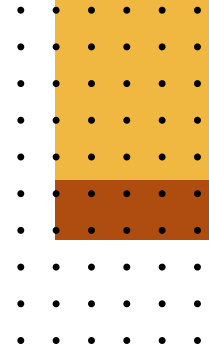

We are the longest established manufacturer of flawed specimens in the Non-Destructive Testing (NDT) and Evaluation (NDE) industry, being internationally accepted as the standard for NDT training and qualification.

Founded in 1980, we have manufactured thousands of flawed specimens for many of the major performance demonstration, training and qualification centers around the world.

With offices in Lancaster, UK and Charlotte, USA, we pride ourselves in pioneering many 'industry standard' flaw manufacture and implanting techniques.

www.sonaspection.com

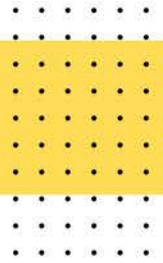

A set of miniature welds, macro sections and photoradiographs to demonstrate the principles of flaw detection, flaw interpretation and basic sizing.

Our educational kits can be made of four different materials: carbon steel, stainless steel, aluminum and 3D printed resin. Our 3D printed resin kits weigh just 3.5kg, making them over 75% lighter than their carbon steel counterpart, and are easier to handle, transport and store. All educational kits are presented in a durable polypropylene



COMPANY PROFILE

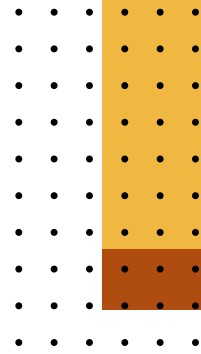

CLEAN AIR
INDUSTRIES

Since its founding in 1992, Clean Air Industries has pioneered advancements in air filtration technologies, delivering solutions that protect workers and the environment from harmful industrial pollutants. Our legacy is built on innovation, driven by a commitment to excellence and sustainability. From small workshops to large manufacturing plants, our solutions are designed to meet the most stringent air quality standards, ensuring a safer workplace and a cleaner planet.

At Clean Air Industries, we pride ourselves on our commitment to crafting exceptional air cleaning solutions entirely in-house. Unlike many competitors who rely on assembling imported components, our manufacturing operations are centered in the United States, with state-of-the-art facilities located in Rome, Georgia, and Russellville, Kentucky. This domestic approach empowers us to maintain stringent quality control measures at every step of the process, ensuring that every product we deliver meets our high standards. Our in-house manufacturing capabilities don't just set us apart; they also enable us to offer unrivaled reliability. By eliminating dependency on overseas supply chains, we can guarantee shorter lead times and faster delivery, getting superior products to you exactly when you need them.

When you choose Clean Air Industries, you're choosing a partner who values quality, efficiency, and American craftsmanship.

www.clean-air.com

BOLT-TOGETHER WELDING BOOTH



Product Benefits

- **Multiple Sizes:** Standard 5' x 5' dimensions with 4' x 4' and 6' x 6' options available.
- **Flexible Configuration:** Booths can be placed side-by-side, back-to-back, or as a stand-alone unit.
- **Cost Efficiency:** With shared side and back walls, you can reduce the overall cost of your project by 30%-40%.
- **Quick Installation:** With a simple bolt together design, you can just unpackage and assemble your booth with minimal effort required.

Product Features

- **Heavy-Duty Construction:** Featuring 12-gauge steel construction designed to withstand punishing training environments.
- **Effective Fume Capture:** Designed to accommodate source capture fume arms or hoods for additional flexibility.
- **Durable Finish:** Powder coated finish in standard CAI blue - custom colors available upon request.

Optional Features

- **J-Hooks:** Wall mounted hooks for ease of storing welding leads.
- **Welding Curtain and Rod:** Red welding curtain and mounting rod for flash protection, spark and ember containment, and safety.
- **Positioners:** Overhead or floor mounted positioners for easy handling of your work piece.
- **LED Light Kit:** Illuminate your workspace when additional lighting is required.
- **Hood Systems:** Source capture selections include backdraft hoods, canopy hoods, or source capture arms.



The Clean Air Industries Bolt-Together Welding Booth is the industry's leading solution for welding labs, training centers, and vocational schools, delivering superior weld fume extraction and safety. Designed for durability and efficiency, our booths create a cleaner, healthier learning environment by effectively capturing hazardous fumes while ensuring compliance with OSHA and AWS safety standards. Manufactured in the USA, our booths are built with industrial-grade materials, ensuring long-lasting performance in even the most demanding training environments. The modular, scalable design allows for multiple sizes (4x4, 5x5, 6x6) to meet the needs of any facility. With a simple bolt-together assembly, installation is fast and straightforward, minimizing labor costs and downtime. Trusted by educators and industry professionals, the Clean Air Industries Bolt-Together Welding Booth sets the standard for air quality, durability, and ease of use.

WELD STATION



Product Benefits

- **No Ducting Required:** Save on expensive start-up costs and valuable space associated with the installation of ducting. The WeldStation is a self-contained system.
- **Capture Airborne Contaminants At Source:** Contains and eliminates harmful weld fumes before they can spread within your facility.
- **Flexibility:** Ducted systems are a fixed solution, making layout changes or facility expansions a costly challenge. The WeldStation offers unmatched flexibility. Its modular design allows you to adapt quickly by repositioning booths or seamlessly adding more as your needs grow. Booths can be installed side-by-side and/or back-to-back.

Product Features

- Single and dual booth configurations available to address your needs
- Built-in tool board
- Integrated weld curtain locks in with a button pin
- Simple filter replacement featuring our new cam lock design
- Knock out holes for electrical needs
- VFD Standard for increased energy savings, noise reduction, and motor speed control
- Two 1" pulsing valves – auto or manual
- 1" NPT compressed air connection – 70-90 PSI required
- [ADA compliant](#)

Optional Features

- Bar-grated table
- Small and large part bins
- Welder shelf
- Hooks
- Customizable logo

Filter Information

- **Two-Stage Spark Arrestors:** Two 24" x 24" x 2" Metal Spark Baffle Filters and two 24" x 24" x 2" Metal Mesh Filters
- **Filter Cartridges:** Four Fire Retardant filters with 226 ft² of media (904 ft² total) – also available in High Efficiency Nanofiber

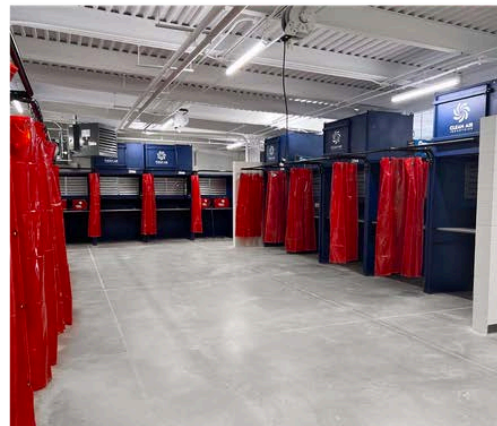

The WeldStation™ is a ductless fume extraction solution trusted by hundreds of trade schools and welding labs across North America. Engineered for adaptability, the WeldStation is available in single or dual booth configurations, giving you the flexibility to meet your workspace needs. Its ductless design and powerful 4,000 CFM of airflow ensure seamless, heavy-duty performance without the hassle of additional accessories or fume capture arms. Crafted with pride in the USA, the WeldStation features rugged 12-gauge, powder-coated steel construction for unmatched durability. Its self-contained, plug-and-play design streamlines installation, cutting costs and saving valuable time. Simply position the WeldStation, connect power, and you're ready to weld. No ducts. No delays. Just a smarter, cost effective solution built for demanding training environments.

AMTECH STREAMER AMBIENT TOWER



Product Benefits

- Eliminates dust and fume from your environment
- Designed to work 24/7 even in high demand applications
- Clean Air Industries can offer turn-key installation
- Removes harmful particles including bacteria
- Main filter life exceeds the industry standard
- Fire Suppression Available

Key Product Features

- Space Saving
- Optional VFD packages for energy savings
- Heavy-duty cabinet construction made in the USA
- Filter Cleaning
- Handsfree

Key Applications

- Manual Welding
- Robotic Welding
- General Ambient Dust
- Designed for 24/7 operations

Why the Amtech Streamer?

- Keep a clean work environment you're proud to show your customers
- Attract top talent with a safe workspace
- American made with quick service and support when required
- Reliable units that have been pushing the industry standard forward for over 30 years.

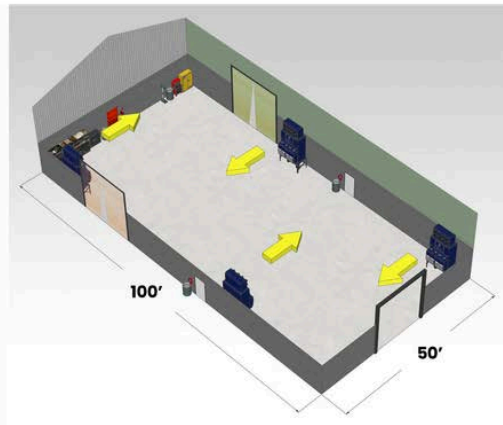

The Amtech Streamer Ambient Tower by Clean Air Industries provides an efficient solution for welding shops, ensuring continuous air changes to maintain a clean working environment. Its compact design optimizes shop floor space by being placed in a staggered formation against walls, reducing obstruction. Unlike traditional hanging units requiring frequent maintenance, the Amtech Streamer integrates a cleaning system similar to a dust collector, decreasing the need for filter changes. Moreover, it operates hands-free, eliminating the need for operator intervention, unlike portable weld fume extractors. With a reputation for reliability backed by 30 years of manufacturing experience, these units are built to last. Plus, they are proudly made in the USA, ensuring quality control from steel cutting to powder coating in Russellville, Kentucky.

LIBERTY PORTABLE WELD FUME EXTRACTOR



Product Benefits

- Capture harmful airborne contaminants, such as dust and weld fume, at source; before they can enter your breathing zone.
- Compact design and easy to maneuver.
- Compliant with OSHA guidelines for the safe capture of weld fumes and smoke.
- Best in-class draw distance and filter life.

Key Product Features

- **Heavy Duty Construction:** Featuring 12-gauge powder coated steel.
- **Steel Constructed Fume Arm:** Powder coated steel fume arms hold up under tough work environments as opposed to the plastic construction many portables use.
- **Cleaning System:** Using a unique internally rotating cleaning wand with a continuous air stream, the filter life on a Liberty P1200 portable is about 6-7 times longer than traditional reverse pulse systems used with competing portable fume extractors.
- **Tool Racks:** Tool racks, cup holders, and tool tray are standard and allow for you to conserve valuable floorspace and always have your tools on hand while remaining safe.
- **Built-In Spark Arrestance:** Includes one (1) 14"x14"x2" fire-retardant metal mesh pre-filter
- **Plug and Play:** 120V, single-phase, 1.5 HP motor.
- **Easy Mobility:** Featuring four (4) industrial-strength lockable swivel caster wheels for effortless transport within your facility.

Filter Information

The Liberty Portable Weld Fume Extractor features two stage filtration. A metal mesh prefilter for spark arrestance followed by a horizontally-mounted 80/20 blend Cellulose/Polyester Cartridge Filter for welding smoke and fume capture.



**DURABLE
CELLULOSE
POLYESTER
CARTRIDGE
FILTER**

Eliminate harmful airborne contaminants at source with the Liberty Portable Weld Fume Extractor by Clean Air Industries. Featuring 1200 CFM of air flow, the Liberty Portable Weld Fume Extractor will consistently outperform competitive units with a draw distance of nearly two feet, so you don't need to constantly re-adjust placement. Highly-durable and whisper-quiet, owing to its built-in acoustical lining in the blower compartment.

DFX AMBIENT AIR CLEANER



Designed for Your Needs

Each DFX Ambient System is designed specifically for the facility layout to optimize filtration throughout the plant. Our sales and engineering team work together with you to design a layout of the system that will work for you.

To correctly design your DFX Ambient System, an in-depth evaluation of your building layout and operation must be completed.

The evaluation includes:

- Application/manufacturing process
- Operator procedures
- Existing ventilation and air movements
- Overall volume and general construction of the building and obstructions.

Upon evaluating your facility, our team will provide you with an engineering design specification and system quotation. These will include system layout, system recommendation, and list of system components.

How It Works

The Clean Air DFX Ambient Air Cleaner is a compact, continuous-duty and self-contained ambient air cleaning system. Each unit consists of housing with fan, motor, integral, silencer and filters. The pollutant air enters the system at the filter side of the system and moves through various filters to achieve the desired cleaning. The air is then exhausted by the blower fan wheel through the acoustically lined blower's side outlet.

The backward incline blower wheels and TEFC energy efficient motors ensure high performance even when the filters are getting dirty. The TEFC energy efficient motor/blower package is direct drive and does not require any maintenance, unlike other belt driven motors. The components are housed in a very sturdy cabinet that will handle many years of use in an industrial environment. Filters ranging from 95% ASHRAE to 99.97% DOP HEPA efficiency are available as well as odor eliminating filters and more.

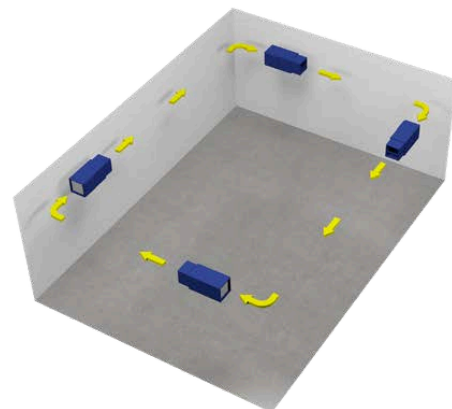

When production applications such as welding, plasma/laser cutting, gouging, and grinding are in use, a layer of smoke and particulates can form if proper filtration is not put in place to capture airborne pollutants within your facility. Clean Air Industries designed the DFX Ambient Air Cleaner Series to effectively eliminate smoke and particulate from the air you breathe. This system is traditionally used in large parts manufacturing environments or where overhead cranes are in use, eliminating the ability for source capture. An ambient system can also be used as a second layer of defense to capture any particles that may have eluded a source capture unit. DFX Ambient Air Cleaners can be hung in a circular pattern from the ceiling, can be set on legs, and can be connected to ducting for direct source capture. DFX Ambient Air Cleaners can house a wide variety and combination of filters for general dust collection and other industrial applications.

LIBERTY WELD CELL COLLECTORS



Product Benefits

- Eliminates dust and fume from your environment
- Limited footprint preserves valuable floor space
- Low cost of ownership

Product Features

- Standard VFD
- EVO Controls, control unit from your phone
- Automatic maintenance notifications
- Convertible into Ambient Units
- Customizable with Oasis™ Flat Hoods
- Industry-leading Internal Static Pressure and Lower Can Velocity

Key Applications

- Robotic Welding
- Stick, MIG, or TIG
- Manual Welding

Why the Liberty Series?

- Keep a clean work environment you're proud to show your customers
- Attract top talent with a safe workspace
- American-made with quick service and support when required
- Reliable units that have been pushing the industry standard forward for over 30 years



The Clean Air Liberty Weld Cell Collector offers a compact robotic weld cell solution with advanced controls. Its compact design, measuring only 42" W x 46" D, maximizes performance in minimal floorspace. Modular flat hoods minimize height requirements and offer custom sizing without added costs. The EVO controls provide automatic notifications for maintenance via app or email, simplifying PM scheduling. Quick installation is facilitated by pre-wired controls, ensuring compliance and cost effectiveness. Manufactured entirely in the USA, the system is easy to maintain with an accessible dust tray for quick cleaning.

DEFENDER PORTABLE 2X3 DOWNDRAFT TABLE



Product Benefits

- Eliminates dust and fume from your environment
- Removes harmful particles including bacteria
- Main filter life exceeds the industry standard
- Fire Suppression Available

Product Features

- 1200 CFM / 265 FPM of airflow
- Solid 12-gauge powder coated steel construction.
- Side & Back Walls: Hinged side and back walls come included with the unit. If you are working on a slightly larger piece, open the side and back walls to make more room.
- Custom Designs & Modular Configurations: Clean Air Industries can modify units to fit your specific Application
- By using a Downdraft Table, you capture the fumes before they can reach your breathing zone. you can keep your welding hood lenses clean so you're not having to constantly replace them.
- Light kit is included

Options

- Automatic Timed Pulse Filter Cleaning system: The filter cleaner engages automatically based on usage, so you don't need to worry about keeping your filters clean.
- Plasma Kit: If you're doing manual plasma cutting, we have a kit that lets you take care of the heavy fume with a strong fire suppression and mitigation kit.

Filter Information

The Defender Portable 2x3 Downdraft Table has a steel anti-spark baffle to help arrest heavy sparks from welding. The next stage of filtration is a metal mesh prefilter followed by a high quality 80/20 blend Cellulose/Polyester Cartridge Filter to capture welding smoke and fumes.



**DURABLE
CELLULOSE
POLYESTER
CARTRIDGE
FILTER**

The Defender Portable 2x3 Downdraft Table by Clean Air Industries is the perfect solution if you're looking for quick & effective source capture of weld fume and grinding dusts. With best-in-class airflow, welders & finishers can simply walk up the table and get to work quickly and safely. This unit offers up to 265 FPM of capture velocity on the table surface. This ensures weld smoke & fumes are captured at source, complying with OSHA workplace guidelines. With its compact plug-&-play form factor, the Defender 2x3 Downdraft Table is an affordable, off-the-shelf solution to keep workers and students safe from harmful welding smoke & fumes or grinding & finishing dust.

DEFENDER INDUSTRIAL DOWNDRAFT TABLES



Product Benefits

- Uniform face velocity across the entire workspace
- Capture contaminants before they enter your breathing zone
- Superior airflow with minimal noise
- Compliant with OSHA guidelines for the safe capture of dust, weld fumes, and smoke
- Automatic self-cleaning filter system for extended filter life
- Ruggedly built in the USA

Product Features

- Modular design
- Quick-release doors for simple filter maintenance
- High capture face velocity
- Dust drawer for easy servicing
- Extinguisher ports for additional safety

Product Options

- 4×3, 4×6, or 4×9 configurations
- Blue cushion grid matting
- Nanofiber filter upgrade
- HEPA afterfilter
- Metal or Lexan back wall, side walls and dividers
- 3', 6' or 9' hoods
- LED light kit
- Gravel tray

Typical Applications¹

- Welding
- Grinding
- Soldering
- Deburring
- Polishing



The Defender Series of Industrial Downdraft Tables by Clean Air Industries is your ultimate source capture solution for weld and soldering fume, grinding dust, and more. Defender Downdraft Tables boast a flexible modular design, available in standard sizes of 4×3, 4×6, and 4×9, ensuring an even face velocity and exceptional airflow between 4200 – 9000 CFM. Engineered to exceed typical industry standards, Defender Downdraft Tables prioritize safety in your workspace. They feature an integrated exhaust silencer to minimize noise and advanced spark arrest technology to maximize safety. Plus, our exclusive quick-release doors make filter rotation or replacement a breeze. The built-in filter cleaning system efficiently dislodges dust, directing it into an accessible dust drawer for quick and easy maintenance. You can customize your Defender Downdraft Table to meet your operational needs, with options including HEPA afterfilters, durable metal or clear Lexan back walls, side walls, and dividers, as well as a gravel tray and LED lighting.

AMTECH EBM ENVIRONMENTAL BOOTHS



Product Features

- Freestanding units can be installed individually or in conjunction with a booth.
- Various sized, self-supporting booth options are available to give workers ample working space.
- Modular, compact design permits proper sizing for each application.
- Front access dust drawers for easy maintenance.
- Easily accessible filter compartments.
- Reverse jet pulse design optimizes filter cleaning and extends filter life.
- No duct work required, reducing installation cost.
- Application-specific filter media maximizes efficiency.
- Recirculates clean air, eliminating the need for expensive make-up air.

Product Options

- Single Station Pulse Timer
- Turbo Digital Pulse Control
- Magnehelic Differential Pressure Gauge
- Washable 100% Spunbond Polyester Filters
- Flame Retardant Nanofiber Filters
- Afterfilters, HEPA 99.97% Efficiency
- Door Set Inlet
- Spark Baffle Inlet
- Backdraft Inlet Louver
- 14" Hopper & Drum Lid Kits with Leg Sets
- Sound Abatement 1" Acoustical Fiberglass Blankets in Panels
- Multiple Base Booth Enclosure Options
- Construction Galvanized Sheet Metal Structure in Panels 18 ga.
- Industrial LED Dust-Tight Light Kits
- Ductwork Design and Fabrication for External Venting



The Amtech EBM Environmental Booth by Clean Air Industries represents the pinnacle of air purification, adeptly capturing airborne contaminants. This state-of-the-art system is specifically engineered to filter a wide array of particulates, including fiberglass, composites, metal finishing by-products, and various fumes, particularly from sizable workpieces. With cartridge options of 6 or 8 and airflow capacities ranging from 4500 to 6000 CFM, the booth's modules efficiently remove smoke, dust, and fumes, safeguarding the operator's health. Its modular design allows customization for specific workspace needs. The advanced reverse jet pulse cleaning system extends filter life and reduces maintenance, making it perfect for managing welding smoke, grinding dust, and various odors.

AMTECH ATV DOWNFLOW CARTRIDGE COLLECTORS



Product Features

- **Zero Velocity Design:** Our unique structure ensures no movement at the base of each filter stack. This lets the dust settle freely below the cartridges, effectively eradicating re-entrainment.
- **High-Quality Cartridge Media:** Comprising 80% cellulose and 20% polyester, our cartridges are rich in resin, ensuring durability. They're designed with pleat-lock construction and can withstand temperatures up to 160°F. Need something for higher temperatures? We've got you covered with our high temperature cartridges.
- **Dual Dust Management:** Our design ensures larger dust particles find their way to the settling area, while finer particles are efficiently captured by the filters.
- **Venturi Reverse Pulse Cleaning:** Experience enhanced cleaning with our quick pressure release system. This method disperses a burst of compressed air uniformly across the filter, offering superior cleaning efficiency compared to conventional reverse pulse cleaning.
- **Optimized Pulse Jet Performance:** We've fine-tuned the orifice size and position to ensure maximum performance and cost-effectiveness. Plus, choose from four jet pulse cleaning.

Additional Features

- Carbon Steel Welded Construction 7 ga./11 ga.
- Base Unit Includes Collector, Legs, Hopper & Turbo Pulse Control
- 55 Gallon Dust Drum & 14" Drum Lid Kits
- Compressed Air Reverse Jet Pulse, Dual 1.5" Valves with Manifolds
- Ground Mount Backward Inclined Blower Class III & IV Construction, Balanced & Tested, 16,000 cfm @ 11" WG / 65,000 cfm @ 16" WG
- Variable Frequency Drive NEMA 12 & NEMA 4 or Magnetic Motor Starter
- Turbo Digital Pulse Control & Cycle Down



Experience enhanced air quality with advanced dust collection technology, adept at handling both delicate and coarse particulates. One significant issue in traditional systems is re-entrainment, which impedes optimal dust collection by agitating filtered dust before it can settle. Effective removal of dust from the filters to the hopper has always been a challenging task, but the Amtech ATV Downflow Cartridge Collector Series by Clean Air Industries offers a proficient solution with options ranging from 8 to 128 cartridges. Our Downflow/Vertical Technology significantly reduces re-entrainment, thereby extending the filter's life. Furthermore, the system's precise control of inlet air velocity ensures air flow is directed strictly downward, preventing any disruptive upward or sideways movement. This careful direction keeps the area below the filters undisturbed, facilitating efficient cleaning during both operation and shutdown. Trust Clean Air Industries for reliable dust collection that contributes to a cleaner, safer environment.

AMTECH ATH HORIZONTAL CARTRIDGE COLLECTORS



Product Features

- **Innovative Downflow System:** Our unique design, featuring horizontally positioned filters and unit-mounted blowers, stands out as a market leader. It's not just about collecting dust; it's about doing it in the most efficient way possible.
- **Optimized Cleaning with Goyen Venturi Assist Design:** Experience the pinnacle of reverse jet pulse cleaning. This design not only ensures better contaminant release but also significantly enhances filter life.
- **Exceptional Filtration Efficiency:** Our high-efficiency cartridge filters boast a 99.7% efficiency rating for submicron (0.5) particulate. This means that even the tiniest of particles won't escape our system. And the best part? The particulate is collected on the outside of the media, ensuring easy maintenance.
- **Uniform Dust Loading:** Thanks to our extra-large circular filters oriented horizontally, dust loading is uniform. This means every part of the filter works equally hard, ensuring efficient cleaning every time.
- **Extended Filter Life and Reduced Maintenance Costs:** With our reverse jet pulse cleaning system, not only do you get longer filter life, but you also benefit from decreased maintenance costs. It's a win-win for your operations and your wallet.

Additional Features

- Carbon Steel Welded Construction 7 ga. / 11 ga. With Heavy Duty Lifting Lugs
- Base Unit Includes Collector, Legs, Hopper & Turbo Pulse Control
- 55 Gallon Dust Drum & 14" Drum Lid Kits
- Compressed Air Reverse Jet Pulse, 1" Valves with Manifold
- Variable Frequency Drive NEMA 12 & NEMA 1 or Combination Motor Starter with Disconnect
- Turbo Digital Pulse Control & Cycle Down

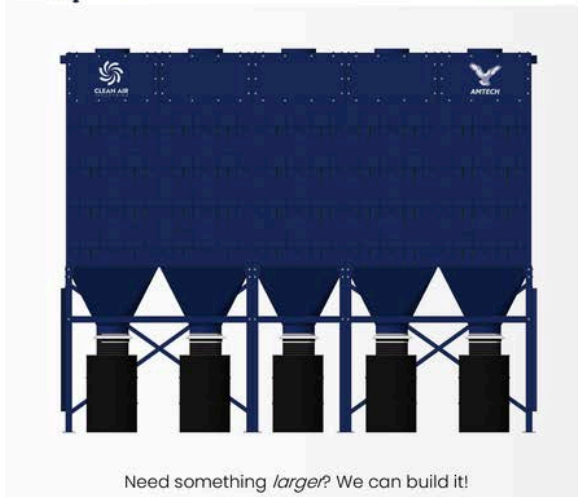

Need something *larger*? We can build it!

Step into a future where air quality is no longer a concern, but a guarantee. In the heartbeat of modern industry, every breath of clean air counts—whether you're at the helm of a bustling workshop, overseeing a high-powered factory, or commanding spaces where even the slightest speck of dust could mean compromise. What you demand is a solution that seamlessly blends efficacy with efficiency. Introducing the Amtech ATH Horizontal Cartridge Collector Series from Clean Air Industries—offering effective protection against airborne impurities, armed with an arsenal of 18 to 80 filter cartridges and an air flow of up to 40,500 CFM. Because in a world that never stops, neither should your pursuit of clean, breathable air.



TRAINING FOR TOMORROW

About Us

Introducing Uneek Educational Solutions

We're Uneek ES, and we can't wait to start working together.

Your vision is important to us. We're eager to map out the needs of your school, your educators and your students.

STEM curriculum is our specialty, so let us help you find the right solutions for tomorrow.

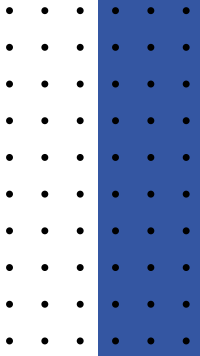

WHAT WE DO

- We are your partner in selecting the right educational programs for your technical focus
- Keep you up to date on new technologies and courses
- Utilize our network of contacts to find a provider that fits your needs

The logo for 'uneek' features the word 'uneek' in a lowercase, sans-serif font. The letters are white and are set against a yellow rectangular background. This yellow background is partially overlapped by a darker orange rectangular shape on the left and top edges. Below the yellow box, the words 'EDUCATIONAL SOLUTIONS' are written in a smaller, uppercase, sans-serif font, also in white.

uneek

EDUCATIONAL SOLUTIONS

12672 Limonite, STE 3E-326
Corona, CA 92880

951-258-1034

ues@uneekeducationalolutions.com

www.uneekeducationalolutions.com